

valor
Heartbeat
OXYSAFE

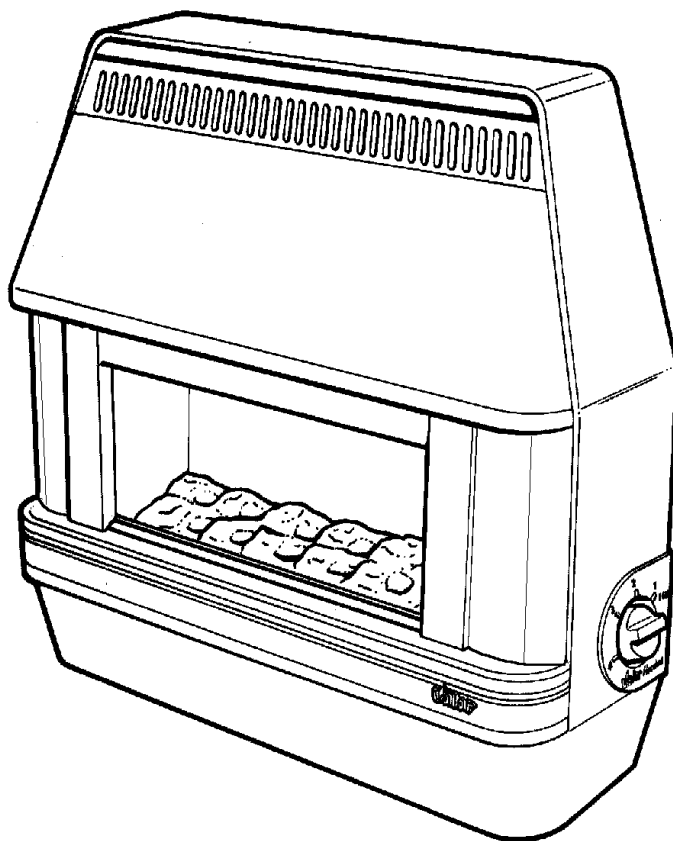

THIS APPLIANCE
IS FOR USE WITH
NATURAL GAS
(G20) AT A SUPPLY
PRESSURE OF
20mbar (8in w.g.)

THIS APPLIANCE
IS FOR USE IN
THE UNITED
KINGDOM (GB)
AND
THE REPUBLIC
OF IRELAND (IE)

**RADIANT / CONVECTOR GAS FIRE
MODEL 426
(GC 32 811 40)**

INSTALLATION & SERVICING INSTRUCTIONS

INSTALLER: Please leave these instructions with the owner

We trust that these instructions give sufficient details to enable this appliance to be installed and maintained satisfactorily. However, if further information is required, our **advice line** will be pleased to help. Ring **0345 626 341** (Local call rates apply)

LIST OF CONTENTS

	Page
Overall dimensions	2
Appliance data	3
General installation requirements.....	3
Fireplace & hearth.....	4
Wall mounted.....	4
Precast flues.....	4
Metal flue box.....	4
Flues.....	4
Unpacking & pre-installation preparation.....	6
Carton contents.....	6
Fireplace flue pull check.....	6
Appliance preparation.....	6
Ignition spark check.....	7
Feet assembly (For floor mounted appliances).....	7
Closure plate fitting.....	8
Appliance installation.....	9
Installing to hearth.....	9
Wall mounting.....	9
Gas supply connection.....	9
Coal & window fitting.....	9
Full operating checks.....	10
Control setting checks.....	10
Reference pressure check.....	10
Final assembly & checks.....	10
Outer case fitting.....	10
Spillage check.....	10
Flame supervision & spillage monitoring system check.....	11
Final review.....	11
Servicing & parts replacement.....	12
Window removal.....	12
Outer case removal.....	12
Coal removal.....	12
Gas tap removal.....	12
Burner, pipes & pilot removal.....	13
Injector removal.....	13
Gas supply pipe disconnection.....	13
Piezo generator removal.....	13
Control tap greasing.....	13
Replacement parts - short list.....	14

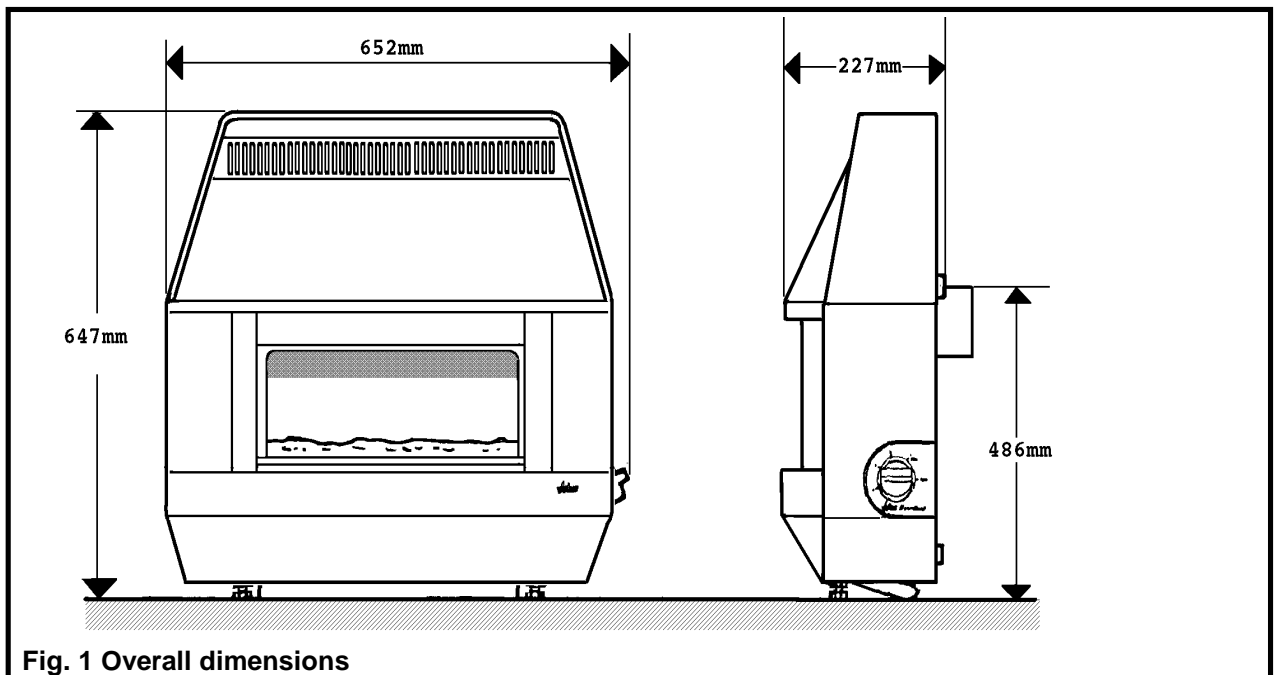

Fig. 1 Overall dimensions

1. APPLIANCE DATA

1.1 This product uses a fuel effect piece containing Refractory Ceramic Fibres (RCF), which are man-made vitreous silicate fibres. Excessive exposure to this material may cause temporary irritation to eyes, skin and respiratory tract. Consequently, it makes sense to take care when handling this article to ensure that the release of dust is kept to a minimum. To ensure that the release of fibres from this RCF article is kept to a minimum, during installation and servicing we recommend that you use a HEPA filtered vacuum to remove any dust and soot accumulated in and around the fire before and after working on the fire. When replacing this article we recommend that the replaced item is not broken up, but is sealed within a heavy duty polythene bag, clearly labelled as RCF waste. This is not classified as "hazardous waste" and may be disposed of at a tipping site licensed for the disposal of industrial waste. Protective clothing is not required when handling this article, but we recommend you follow the normal hygiene rules of not smoking, eating or drinking in the work area and always wash your hands before eating or drinking. This appliance does not contain any component manufactured from asbestos or asbestos related products.

1.2 The appliance data badge is on the inner face of the back panel near the bottom left corner. There is also a label giving a serial number and the appliance G.C number on the right side of the outer case near the bottom.

1.3 General Data

The overall dimensions are shown in fig.1.

Gas:	Natural (G20)
Supply pressure:	20mbar (8in. w.g)
Gas consumption at Control Setting:	Gross Heat Input
4	5.77kW (19,700Btu/h)
3	4.16kW (14,200Btu/h)
2	2.40kW (8,200Btu/h)
1	1.65kW (5,600Btu/h)
Burner type:	Duplex
Injectors:-	Upper: Bray Cat 99 Size 150B Lower: Bray Cat 99 Size 240
Burner test pressure: (cold)	17.46 ± 0.75mbar (7.0 ± 0.3in. w.g)
Pilot & atmosphere: sensing device	SIT ref. OP9044
Control Tap:-	Duplex four position. Fitted with integral piezo-electric igniter and thermocouple activated electro-magnetic shut-off valve.
Inlet connection:	Rp1/4 (1/4" BSP)
Aeration:	Non-adjustable

2. GENERAL INSTALLATION REQUIREMENTS

2.1 The installation should comply with the rules in force.

In your own interest and that of safety, in the United Kingdom, it is the law that all gas appliances are installed by competent persons in accordance with the current edition of the Gas Safety (Installation & Use) Regulations. Failure to install appliances correctly could lead to prosecution.

The Council of Registered Gas Installers (CORGI) requires its members to work to recognised standards. The installation must be in accordance with these instructions.

In the United Kingdom the installation must also be in accordance with:

- All the relevant parts of local regulations.
- The Building Regulations issued by the Department of the Environment or the Building Standards (Scotland) (Consolidation) Regulations issued by the Scottish Development Department.
- All relevant codes of practice.

d) The relevant parts of the current editions of the following British Standards:-

- BS 715
- BS 1251
- BS 1289 Part 1
- BS 1289 Part 2
- BS 4543 Part 2
- BS 5440 Part 1
- BS 5440 Part 2
- BS 5871 Part 1
- BS 6461 Part 1
- BS 6891

In the Republic of Ireland the installation must also conform with the national and local regulations in force.

2.2 The appliance must not stand on a carpet or any other combustible material.

If a panel has to be fitted to the fireplace opening to meet the required opening sizes shown below, it must be made of non-combustible material.

2.3 In the United Kingdom, as supplied, the appliance can be installed in the following situations.

2.3.1 Conventional fireplace and hearth

The appliance can be installed to a fireplace complete with surround and hearth

The fireplace opening must be within the following dimensions:

Width: Max. 432mm
Min: 305mm
Height Max: 610mm*
Min. 510mm

* Though the total height of the closure plate will accommodate a maximum opening height of 650mm, heights above 610mm will leave the closure plate and sealing tape visible above the appliance.

The appliance must be mounted on a non-combustible hearth (N.B. conglomerate marble hearths are considered as non-combustible). The hearth must be at least 710mm wide x 300mm deep. The hearth material must be at least 12mm thick. The periphery of the hearth (or fender) should be at least 50mm above floor level to discourage the placing of carpets or rugs over it. The appliance can be fitted to a purpose made proprietary class "O" 100°C or 150°C surround.

2.3.2. Wall mounted

The appliance can be wall mounted.

The opening must be within the following dimensions:

Width: Max. 432mm
Min. 305mm
Height: Max. 610mm*
Min. 372mm

* Though the total height of the closure plate will accommodate a maximum opening height of 650mm, heights above 610mm will leave the closure plate and sealing tape visible above the appliance.

The centre of the flue spigot must be at least 512mm above the finished floor covering.

2.3.3. Precast flue

The appliance can be installed to a fireplace that has a precast concrete or clay flue block system conforming to BS1289. The appliance is suitable for installations conforming to older versions of BS1289 as well as the current edition. The flue blocks must have a minimum width not less than 63mm and a cross-sectional area not less than 13,000mm². Older editions of BS1289 required a cross-sectional area of 13,000mm². The current revision of the standard requires 16,500mm². This appliance is suitable in both cases.

The chimney should be on or two storeys high but not less than 3m vertical height and be correctly terminated. No mortar fangs between the blocks should be extruded into the flueway. If raking blocks are used, they must be fitted in accordance with the manufacturer's instructions. Mortar must not be allowed to drop down and accumulate in the raked positions.

The fireplace opening must be within the following dimensions:

Width: Max. 423mm
Min: 305mm
Height Max: 610mm*
Min. 610mm*

* Though the total height of the closure plate will accommodate a maximum opening height of 650mm, heights above 610mm will leave the closure plate and sealing tape visible above the appliance.

2.3.4. Metal flue box

The appliance can be installed to a metal flue box complying with the constructional requirements of the current edition of BS715.

The opening must be within the following dimensions:

Width: Max. 432mm
Min: 380mm
Height Max: 610mm*
Min. 510mm

* Although the total height of the closure plate will accommodate a maximum opening height of 650mm, heights above 610mm will leave the closure plate and sealing tape visible above the appliance.

2.4. Flues

The flue must be clear of any obstruction and its base must be clear of debris.

The flue must be completely sealed so that combustion products do not come into contact with combustible materials outside the chimney.

Suitable flues are as follows:-

- (a) 225mm x 225mm conventional brick flue. If a flue liner is used, it must be a minimum of 127mm (5in) diameter. The liner must be sealed to the surrounding area above the fireplace opening and to the top of the chimney with an approved terminal being used.
- (b) A properly constructed precast flue conforming to B.S 1289.
- (c) A flue pipe with a minimum diameter of 127mm (5in.). See B.S 6461 Part 1 for suitable materials. Metal flue pipes must comply with B.S 715. See section 2.3.4 of this manual for flue box opening sizes.

2.4.1 The flue must have a minimum equivalent height of 3m.

2.4.2. The flue must serve only one fireplace.

2.4.3 Any damper or register plate should be removed. If removal is not possible without carrying out structural work, the damper or plate may be left in the flue *provided that it is permanently secured in the fully open position.*

2.4.4. If the appliance is intended to be installed to a chimney which was previously used for solid fuel, the flue must be swept clean prior to installation. All flues should be inspected for soundness and freedom from blockages.

2.5 If the fireplace opening is an underfloor draught type, it must be sealed to stop any draughts.

2.6. The flue spigot and any spigot extension must be capable of passing through the closure plate by at least

25mm with a minimum clearance of 50mm between its open end and the nearest obstruction.
 There must also be a minimum clearance of 165mm between the back of the closure plate and the back of the catchment space.
 The catchment space below the flue spigot must extend at least 250mm downwards measured from the bottom of the flue spigot.
 See figure 2.

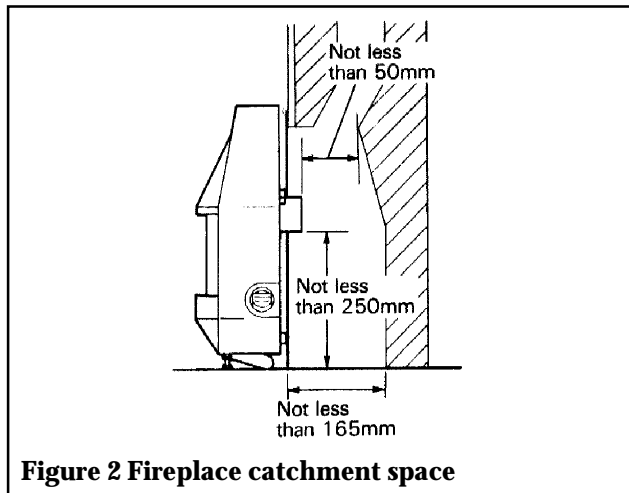

Figure 2 Fireplace catchment space

2.7. If the fire is to be fitted against walls with combustible cladding, the cladding must be removed from the area shown in fig.3.

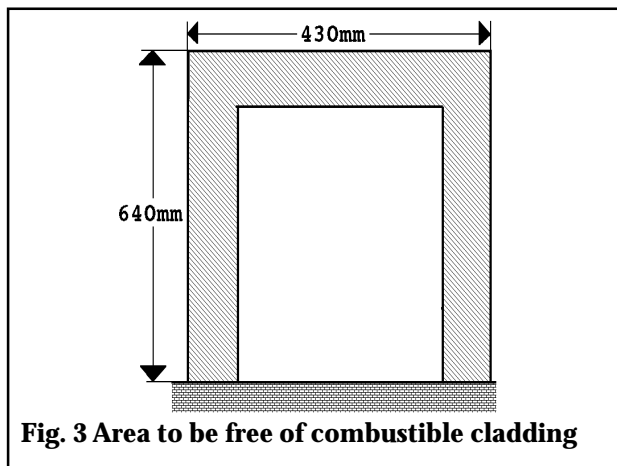

Fig. 3 Area to be free of combustible cladding

2.8. The front of the fireplace should be flat over an area sufficient to ensure a good seal with the closure plate. The flat surface should extend for a height equal to that of the closure plate plus 20mm and a for a width equal to that of the closure plate plus 40mm.

2.9. The minimum clearance from the top surface of the appliance to the underside of any shelf made from wood or other combustible materials is as follows:-

- *For a shelf up to 150mm deep*
Minimum clearance = 150mm
- *For a shelf deeper than 150mm*
150mm + 12.5mm for every 25mm depth over 150mm.

2.10. The minimum allowable distance to a corner wall or any other projection at either side of the appliance is 100mm.

2.11. The space between the fireplace front face and the back of the outer case must not be filled in.

2.12. Please note that soft wall coverings (e.g. embossed vinyl etc.) are easily affected by heat. They may, therefore, scorch or become discoloured when close to a heating appliance. Please bear this in mind when installing.

2.13. An extractor fan may only be used in the same room as this appliance, or in any area from which ventilation for the appliance is taken, if it does not affect the safe performance of the appliance. Note the spillage test requirements detailed further on in this manual. If the fan is likely to affect the appliance, the appliance must not be installed unless the fan is permanently disconnected.

2.14. In the United Kingdom no special ventilation bricks or vents are required in the room for this appliance.

In the Republic of Ireland permanent ventilation must comply with the regulations currently in force.

3. UNPACKING & PRE-INSTALLATION PREPARATION

3.1. Carton Contents

The carton contains the following:-

1. Fire assembly.
1. Ceramic fuel effect (In packaging inside firebox).
1. Closure plate.
1. Flue spigot.
1. Pair of feet (for floor mounting the appliance).*
1. Pair of feet shrouds (for floor mounting the appliance).*
1. Pack of fixings containing:
 2. Plastic caps for foot screws.
 - 4 No 8 tapping screws for flue spigot
 - 4 Woodscrews for wall mounting
 - 4 Wall plugs
 - 2 Knurled screws for feet shrouds
 - 4 M5 screws for feet
1. Inlet elbow connector.
1. Smoke match tube.

Remove all the items carefully to prevent damage. Some items may be contained in the packaging fitments - Examine the packaging carefully before discarding. Check that all the items are present and undamaged.

*The polystyrene top fitment containing the feet and feet shrouds indicates which items are for the left and right sides. To ease identification at the assembly stage, leave the parts in the polystyrene until you are ready to fit them.

3.2. Fireplace Flue Pull

After preparing the fireplace, apply a lighted match, paper or smoke match to the chimney opening. Observe the smoke. If there is a definite flow into the opening continue with the installation. If there is not a definite flow, preheat the chimney for a few minutes and recheck. If there is still no definite flow, the chimney may need attention. **Do not fit the appliance. Seek expert advice.**

3.3. Appliance Preparation

3.3.1. Stand the fire upright.

3.3.2. Detach the window surround (See figure 4):

- a) Remove the two knurled screws immediately below the outer case canopy.
- b) Lift the surround clear of the slots in the outer case apron

3.3.3. Remove the control knob by pulling clear of the gas tap spindle.

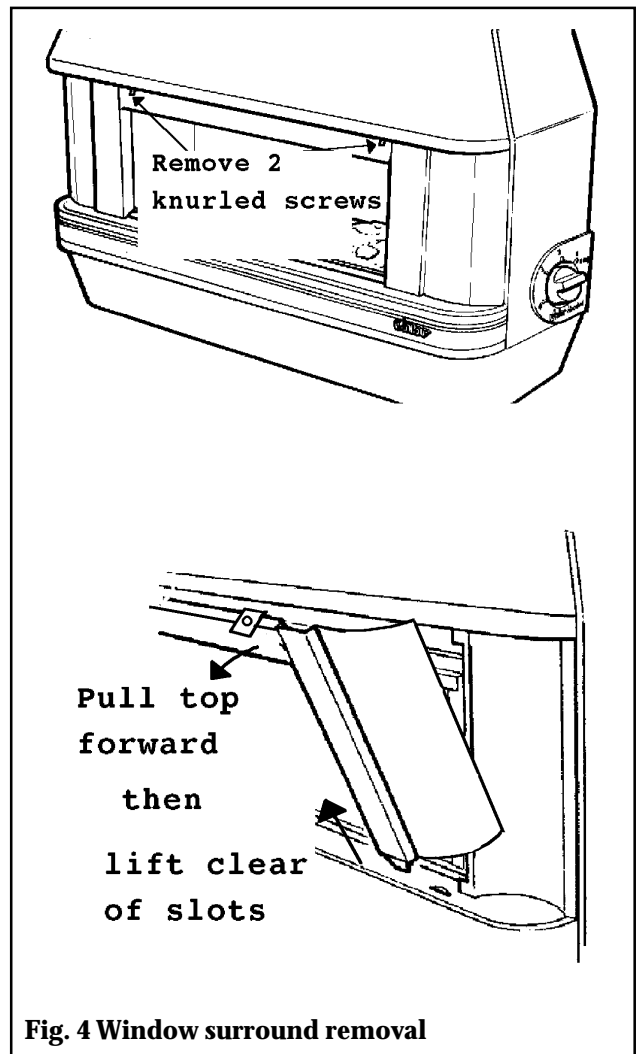

3.3.4. Remove the control bezel by unscrewing two screws (see fig.5).

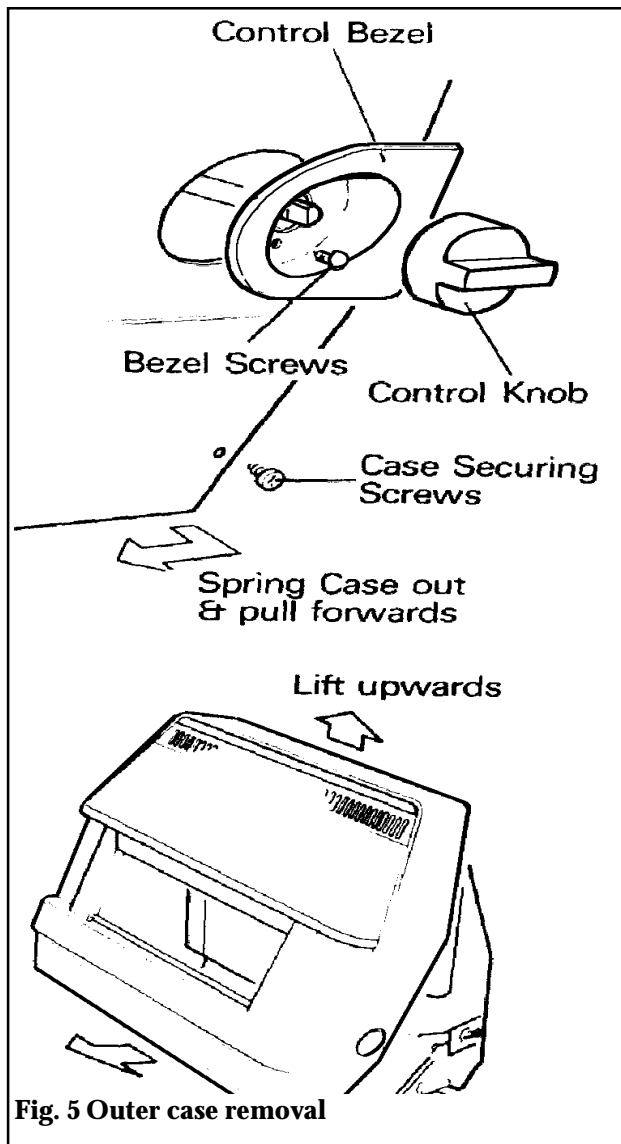

3.3.5. Detach the outer case by removing the screws at the case sides (see fig.5).

3.3.6. Pull the bottom of the case forwards while springing the bottom corners outwards to clear the fixing brackets. Lift the case upwards and forwards to clear (see fig.5). Place carefully to one side.

3.3.7. Remove the window unit by detaching the knurled screws at the bottom corners. Lift the window unit up to clear the top flange of the firebox and place carefully aside (see fig.6).

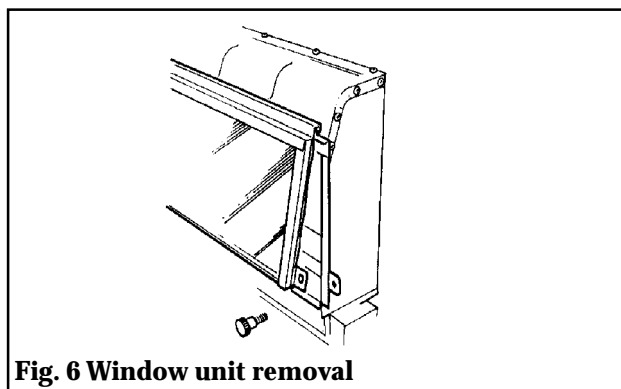

3.3.8. Check ignition spark

Before attempting to install, it is worth checking that the piezo electric spark ignition system operates satisfactorily.

To initiate the spark, temporarily refit the control knob to the tap spindle. Depress the control knob and while keeping it depressed, turn anticlockwise through approximately 60° to the 1/IGN position. A spark should track from the electrode pin to the thermocouple tip. If there is no spark or incorrect tracking, check the spark gap between the electrode wire and thermocouple tip (see figure 7). If the spark gap is correct, check the ignition wiring.

Remove the control knob after checking.

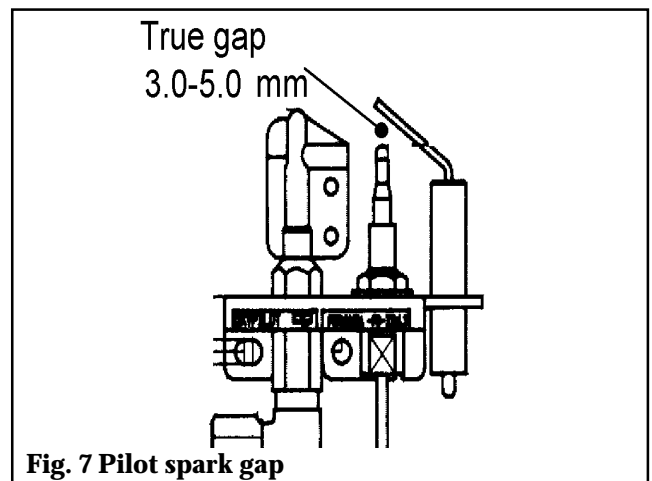

3.3.9. For floor mounted appliances

3.3.9.1 Fit the shrouds to the feet with the knurled screws supplied (see figure 8). Slide the shrouds up to the feet as far as they will go. Tighten the knurled screws.

Identification of the left and right side components is shown on the polystyrene fitment containing the parts.

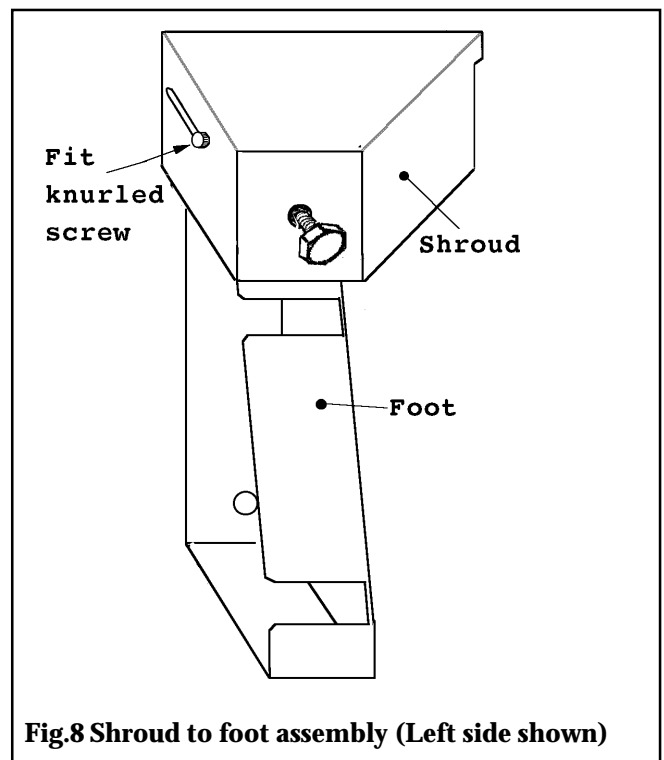

3.3.9.2 Fit the feet to the underside of the appliance feet mounting brackets (See figure 9).

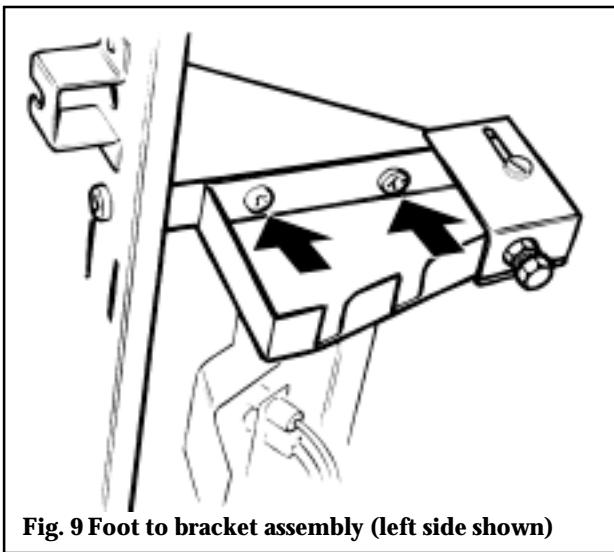

Fig. 9 Foot to bracket assembly (left side shown)

3.3.10 Fit the flue spigot to the back of the fire using four screws provided.

3.3.11 If the fire is fitted to a recessed fireplace, an extension flue spigot up to a maximum total length of 125mm may be used. The extension must be a tight fit over the flue spigot and be secured by two self tapping screws. Note the minimum clearance required as shown in figure 2.

3.4 Fit The Closure Plate (Figs 10, 11 & 12)

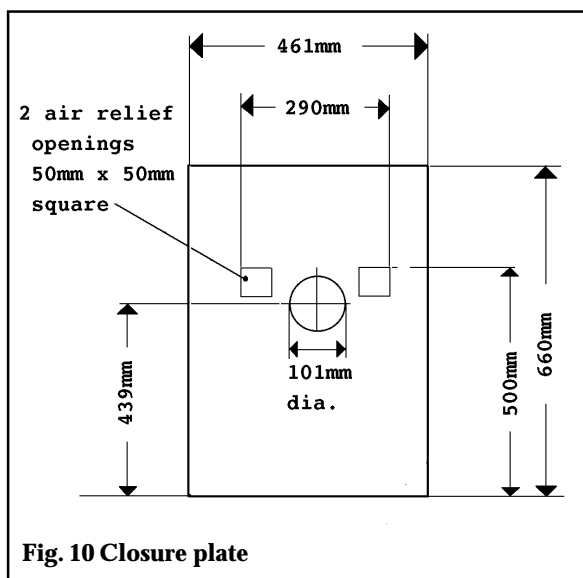

Fig. 10 Closure plate

3.4.1. If a centre gas pipe connection is required cut an opening at the bottom of the closure plate. (The gap between the pipe and the opening in the closure plate should be sealed with tape after connection.)

3.4.2. Hearth mounting (figure 11)

The closure plate must be fitted and sealed to the hearth and fireplace opening using a suitable heat resistant material. If necessary cut the closure plate. Leave the closure plate sufficiently large to overlap the fireplace

opening by 25mm. Make sure that the rectangular air relief openings are fully within the fireplace opening.

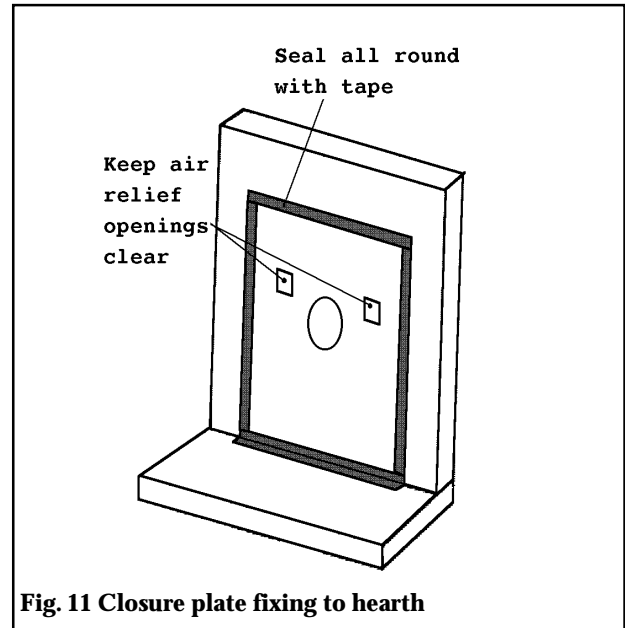

Fig. 11 Closure plate fixing to hearth

3.4.3 Wall mounting (Figure 12)

The closure plate must be fitted and sealed to the fireplace opening using a suitable heat resistant material. If necessary cut the closure plate. Leave the closure plate sufficiently large to overlap the fireplace opening by 25mm. Make sure that the rectangular air relief openings are fully within the fireplace opening.

The underside of the outer case must be at least 115mm above any carpet or other floor covering. To achieve this, the centre of the flue spigot hole will be at least 512mm above the finished floor covering.

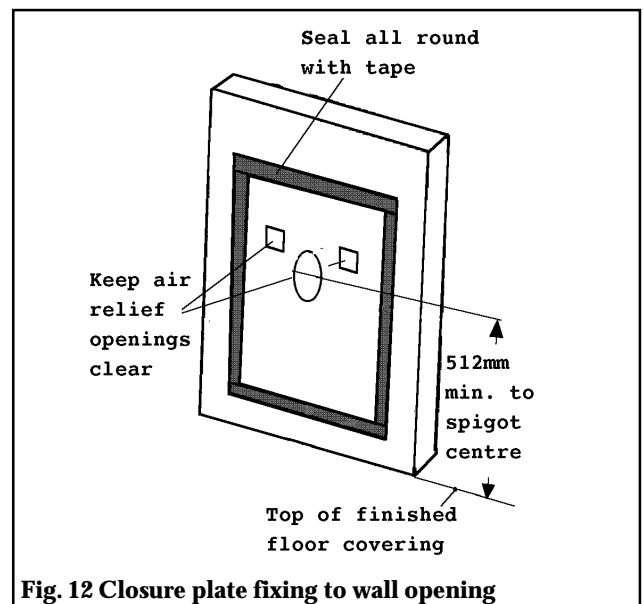

Fig. 12 Closure plate fixing to wall opening

3.4.4. Check the flue pull with closure plate fitted by applying a lighted match or smoke match to the flue spigot opening in the closure plate and observe the smoke. If there is a definite flow continue with the installation. If not check the fitting of the closure plate. The fireplace flue pull check described in section 3.2 should have confirmed that the fireplace itself is satisfactory.

4. APPLIANCE INSTALLATION

4.1 Installing To A Hearth

4.1.1. The levelling screw lock nuts should be accessible below the shrouds. If necessary, loosen the knurled screws securing the shrouds, raise the shrouds and resecure them. To prevent scratching the hearth, fit the two plastic caps (Supplied in the accessory pack) over the heads of the levelling screws. See figure 13.

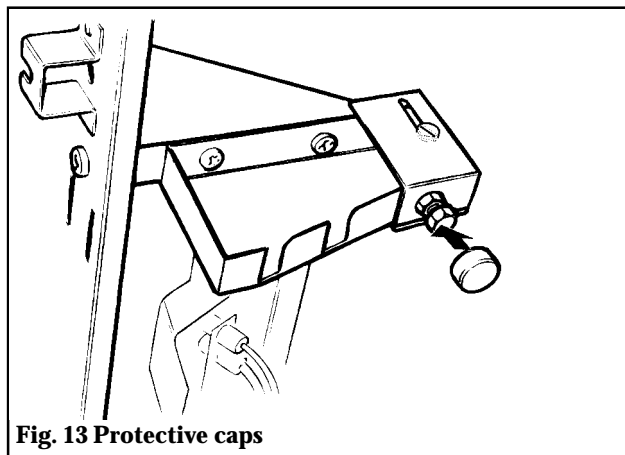

4.1.2 Place the fire centrally on the hearth making sure that the spigot lines up with the spigot hole in the closure plate. Gently slide the appliance into place. The spigot must enter the closure plate to a depth of at least 25mm.

4.1.3 Level the fire by loosening the lock nuts and turning the levelling screws in the feet up or down as required while they bear on the hearth. When the fire is level and square to the wall, retighten the lock nuts. Loosen the knurled screws securing the feet shrouds and lower the shrouds until they cover the levelling screws.

4.2 Wall Mounting

The position of the wall fixing holes in relation to the closure plate spigot hole are shown in fig. 14.

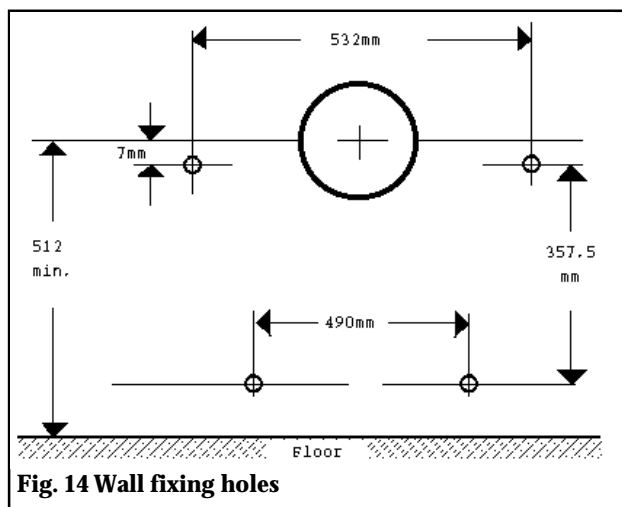

4.2.1 Mark the positions of the two upper fixing holes using the dimensions as shown in fig. 14. The positions can alternatively be marked by placing the fire in position and marking the wall through the upper holes in the back panel.

4.2.2 Drill and plug the holes. Fit a woodscrew in one hole. Leave about 12mm gap between the screw head and the wall to hang the fire.

4.2.3. Hang the fire on the upper screw making sure that the flue spigot engages through the closure plate.

4.2.4. Mark the positions of the bottom fixing holes through the back panel, ensuring that the fire is level.

4.2.5. Remove the fire. Drill and plug the bottom fixing holes.

4.2.6. Replace the fire. Fit three woodscrews, two through the bottom holes and one through the remaining top hole. Tighten all four woodscrews.

4.3. Gas Supply Connection

4.3.1. An Rp1/4 (1/4in. B.S.P.) elbow connector is provided. This can be revolved through 360° to the connection position required. If a rear centre connection is required through an opening cut in the closure plate (see section 3.4.1.), seal the gap between the plate and the pipe with tape after connection.

4.3.2. Provision for isolation of the gas supply must be provided upstream of the appliance for safety and servicing.

4.3.3. The supply pipe must be of a rigid material (e.g. copper). A flexible connection must not be made.

4.3.4. Pressure check the installation pipework for gas soundness in accordance with the current edition of BS6891.

4.4 Fit Coal And Window

4.4.1. Place the coal bed in position. Make sure that the coal rests on the ledges at the sides of the firebox and that its back face is touching the back of the firebox.. (see fig.15).

4.4.2. Replace the window unit, making sure its top channel locates over the top flange of the firebox opening. Refit the two knurled screws and tighten.

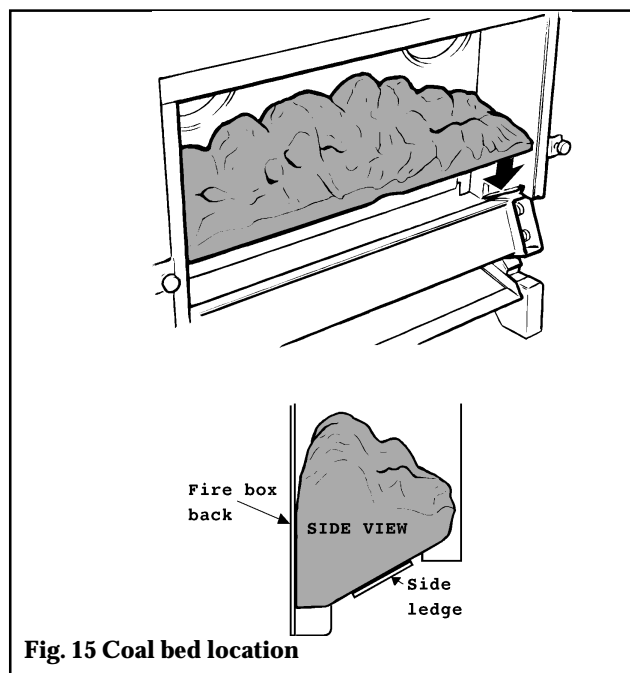

Fig. 15 Coal bed location

5. FULL OPERATING CHECKS

5.1 Check Control Settings

5.1.1. To help in checking the control positions while the outer case is detached, place the control bezel over the gas tap spindle and against the tap bracket. Temporarily secure to the tap bracket with one of the screws.

5.1.2. Fit the control knob over the gas tap spindle.

5.1.3. Depress the control knob and turn anticlockwise partially towards the 1/IGN position until some resistance is felt. Keep depressed at this position to purge air from the system then, while keeping it depressed, turn fully to the 1/IGN position. A spark should be generated at the pilot while turning. The spark should ignite the pilot.

5.1.4. When pilot ignition has been achieved, keep the control knob depressed for approximately ten seconds to allow the thermocouple probe to warm up and then release it. If the pilot does not remain alight, ensure that the air has been purged, that the pilot orifice is clear and that the thermocouple connections are sound. Replace the pilot unit if necessary (see servicing section of this manual).

5.1.5. Check all the control settings. These are:-
Knob

<u>Position</u>	<u>Burner appearance</u>
1/IGN	Centre section on low. Outer sections off.
2	Centre section fully on. Outer sections off.
3	Centre section fully on. Outer sections on low.
4	Centre and outer sections fully on.

5.2. Check Reference Pressure

The appliance is pre-set to give the correct heat input at the inlet pressure shown in section 1 of this manual. No adjustment is necessary. Check the burner pressure by fitting a pressure gauge at the test point. The test point is on the pipe connecting the gas tap to the lower injector. Check the pressure with the appliance alight and set at maximum output (Control position 4).

After checking, turn off the appliance. Remove the pressure gauge and replace the test point sealing screw. Relight the appliance. Turn to the maximum output position and test around the sealing screw for gas soundness with a suitable leak detection fluid.

6. FINAL ASSEMBLY & CHECKS

6.1 Fit The Outer Case

6.1.1. Detach the control knob and control bezel.

6.1.2. Refit the outer case. Make sure that the centre strip at the top back of the case is located behind the vertical face of the back panel.

The rearward angled ears near the top corners of the back panel should be behind the outer case top plate, (see fig.16).

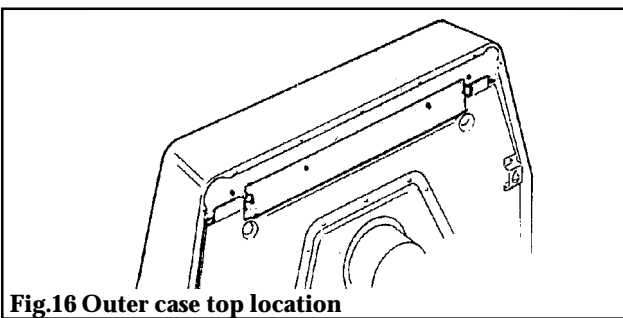

Fig.16 Outer case top location

6.1.3. Secure the case at the bottom sides with the two screws previously removed.

6.1.4. Place the control bezel back in position and secure it to the gas tap bracket with two screws.

6.1.5. Fit the control knob over the gas tap spindle.

6.1.6. Make sure that the coal is not dislodged when refitting the case.

6.1.7. Refit the window surround using the two knurled screws previously removed (The reverse method to that described in section 3.3.2). *Make sure that the outer edges of the surround sides are inside the outer case.*

6.2. Test For Spillage

A spillage test must be made before the installed appliance is left with the customer.

6.2.1. Close all doors and windows in the room containing the fire.

6.2.2. Light the appliance and set the control knob to the maximum position (Position 4).

6.2.3. Leave the appliance on for five minutes.

6.2.4. There are two types of smoke match holders. One has a copper finish, the other is plain steel. Please apply the relevant parts of the spillage test instructions

Place the smoke match tube (with lighted match) on top of the wall spacer bracket at the rear right side of the appliance.

Copper finish tubes: Slide the tube in until the second indent is level with the outer edge of the spacer bracket. A raised ring round the tube (approx. 25mm from the indent) should be visible along the casing side (see fig.17).

Plain steel tubes: Slide the tube until the indent is level with the edge of the casing side (see fig.17).

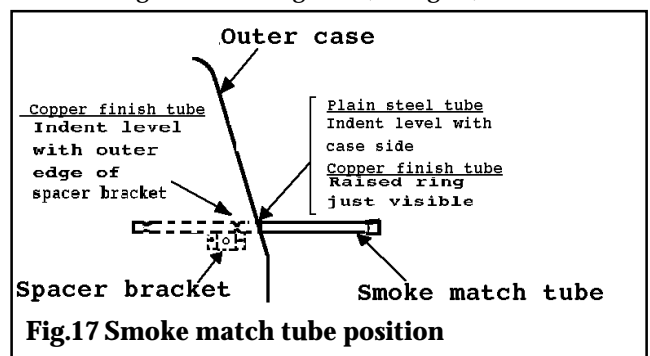

Fig.17 Smoke match tube position

The installation is satisfactory if all the smoke is drawn into rectangular opening in the closure plate. If any smoke is escapes from the top or side of the appliance, leave the appliance alight at the maximum setting for a further ten minutes and then repeat the test. If all the smoke is still not drawn into the closure plate opening,

Disconnect the appliance and seek expert advice.

6.2.5. If the above test is satisfactory, open all internal connecting doors, hatches, etc. in the room. Keep all doors and windows that open to the outside of the building closed. recheck for spillage as above. If an extractor fan is installed in the same room as the appliance or a connecting room, check that spillage does not occur with the fan operating and all doors and other openings between the fan and the appliance open. If all the smoke is drawn into closure plate opening, continue with the installation. If the test is not satisfactory,

Disconnect the appliance and advise the customer of the cause of failure.

6.3 Flame Supervision & Spillage Monitoring System

This pilot unit incorporates a system which will automatically shut off the gas supply if the pilot flame goes out or if there is insufficient oxygen due to spillage or lack of ventilation.

Check that the system operates properly as follows;

6.3.1 Light the appliance. Set at position 4 and leave for one minute.

6.3.2 Turn back to "OFF" to extinguish the pilot. ***Note the time when the pilot goes out.*** Listen for a snap sound at the gas tap. ***Note the time when the sound is heard.*** This sound is caused by an electromagnetic valve shutting off the gas supply through the tap. The valve is located in the body of the tap. The valve should operate ***within 60 seconds of the pilot going out.*** If the valve does not operate within this time limit do not allow the appliance to be used until the fault has been corrected.

This monitoring system must not be adjusted, bypassed or put out of operation.

This monitoring system, or any of its parts, must only be exchanged using Valor authorised parts.

7 FINAL REVIEW

7.1 Make sure that the floor plate has been refitted.

7.2 Recheck the operation of the fire at all control positions.

7.3. Visually inspect the appliance. Clean off any marks incurred during installation.

7.4 Advise the customer how to operate the fire.

7.5 Explain to the customer that the appliance has a flame failure and spillage monitoring system. Point out the explanation of this system shown in the owner's guide.

7.6 Advise the customer that, if the igniter fails, the fire can be lit with a match as described in the users instructions.

7.7 Advise the user that the window will require cleaning periodically outside and inside as described in the users instructions. Explain how to remove and

replace the window unit for cleaning the inside of the glass etc.

7.8 Advise that the fire may give off a slight odour while new. This is quite normal and it will disappear after a short period of use.

7.9 Advise that any cleaning must only be carried out when the fire is off and cold.

7.10 Advise the customer that they should read their Owner's guide before operating the fire and always follow the advice in the section headed "Cleaning your fire".

7.11 Recommend that the appliance should be serviced and the chimney inspected by a competent person at least annually.

7.12 Hand these instructions and the owner's guide to the customer.

8. SERVICING & PARTS REPLACEMENT

- *Always turn off the gas supply and make sure that the appliance is cool before commencing any servicing.*
- *Always test for gas soundness and spillage after servicing the appliance.*
- *It is recommended that, at least once a year, the appliance is disconnected and the catchment space behind the closure plate checked and cleared of any debris. The closure plate must be resealed to the wall after checking.*
- *This product uses a fuel effect piece containing Refractory Ceramic Fibres (RCF), which are man-made vitreous silicate fibres. Excessive exposure to this material may cause temporary irritation to eyes, skin and respiratory tract. Consequently, it makes sense to take care when handling this article to ensure that the release of dust is kept to a minimum. To ensure that the release of fibres from this RCF article is kept to a minimum, during servicing we recommend that you use a HEPA filtered vacuum to remove any dust and soot accumulated in and around the fire before and after working on the fire. When replacing this article we recommend that the replaced item is not broken up, but is sealed within a heavy duty polythene bag, clearly labelled as RCF waste. This is not classified as "hazardous waste" and may be disposed of at a tipping site licensed for the disposal of industrial waste. Protective clothing is not required when handling this article, but we recommend you follow the normal hygiene rules of not smoking, eating or drinking in the work area and always wash your hands before eating or drinking.*

8.1 To Remove Window Unit

- 8.1.1. Detach the window surround by removing the two knurled screws immediately below the outer case canopy and lifting the surround clear of the slots in the outer case apron (See figure 4 in installation section).
- 8.1.2. Remove the window unit by detaching the knurled screws at the bottom corners. Lift the window unit up to clear the top flange of the firebox and place carefully aside (See fig.6 in installation section).
- 8.1.3. Replace in the reverse order.

8.2 To Remove Outer Case (See fig.5 in installation section)

- 8.2.1. Remove the control knob by pulling clear of the gas tap spindle.
- 8.2.2. Remove the control bezel by unscrewing two screws.
- 8.2.3. Detach the outer case by removing the screws at the case sides.
- 8.2.4. Pull the bottom of the case forwards while springing the bottom corners outwards to clear the fixing brackets. Lift the case upwards and forwards to clear.
- 8.2.5. Replace in the reverse order. When refitting, make sure that the plate at the top back of the case is

located behind the vertical face of the back panel but in front of the two rearward angled ears near the top corners of the back panel. The two rearward pointing tabs in the top of the outer case rear plate should locate against the inner edges of the ears on the back panel (See fig.16 in installation section).

8.3 To Remove The Coal

- 8.3.1 Remove the window unit as described in section 8.1
- 8.3.2. Remove the coal.
- 8.3.3. Replace in the reverse order. When replacing, make sure that the coal rests on the ledges at sides of the firebox and that its back face is touching the back of the firebox (see fig.15 in installation section).

8.4 To Remove The Gas Tap

- 8.4.1 Remove the outer case as section 8.2 above.
- 8.4.2. Detach the electrode lead from the pilot unit by pulling the lead down and away from the electrode situated at the centre rear of the burner.
- 8.4.3. Disconnect the two pipes linking the upper and lower injectors at the tap end and loosen their connections at the injector ends. Swing the pipes clear of the tap.
- 8.4.4. Disconnect the inlet pipe and pilot pipe from the gas tap.
- 8.4.5. Remove the locknut holding the gas tap to the tap bracket.
- 8.4.6. Carefully lift the tap clear to allow access to the thermocouple connection. Disconnect the thermocouple from the tap.
- 8.4.7. Replace in the reverse order.

8.5. To Remove The Burner, Pipes And Pilot

- 8.5.1.** Remove the outer case as section 8.2.
- 8.5.2.** Remove the coal as section 8.3.
- 8.5.3.** Detach the gas tap and disconnect the thermocouple from the tap as section 8.4.
- 8.5.4.** Remove the screw and shakeproof washer fixing the burner at the right side
- 8.5.5.** Remove the wing nut fixing the burner at the left side.
- 8.5.6.** Slide the burner unit complete with pilot pipe and main burner pipes and pilot unit to the left and forward clear of the radiant box.
- 8.5.7.** Remove the pipes, injectors or pilot unit if required.
- 8.5.8.** Replace in the reverse order.

Note: 1. The pilot unit must be replaced as a whole assembly. Its individual components are not separately replaceable.

- 2. If removed, ensure that the dust cage is cleaned before refitting and locates squarely onto the pilot unit without any gaps between the cage edges and the pilot unit.*
- 3. Make sure that the pilot shield is refitted if removed.*
- 4. When refitting the burner make sure that the shakeproof washer is fitted under the head of the screw which engages with the right hand burner bracket. This washer prevents the end of the screw from catching the upper injector hexagon.*

8.6. To Remove An Injector

- 8.6.1.** Remove the outer case as section 8.2.
- 8.6.2.** Release the pipe compression fitting to the upper or lower injector as required. Lock the injector with a second spanner to ensure that it does not move.
- 8.6.3.** Loosen the pipe compression fitting at the tap end and move the pipe clear.
- 8.6.4.** Remove the injector from the burner.
- 8.6.5.** Replace in the reverse order.

8.7. To Disconnect The Gas Supply Pipe

Access for gas supply disconnection, may be easier if the floor plate is removed.

- 8.7.1.** Remove the outer case as section 8.2.
- 8.7.2.** Detach the plate by unscrewing two screws securing it to the side feet and pulling clear (see fig.18).
- 8.7.3.** Replace in the reverse order. When refitting the floor plate, make sure that the rear tabs locate through the upper pair of slots in the back panel (see fig.18).

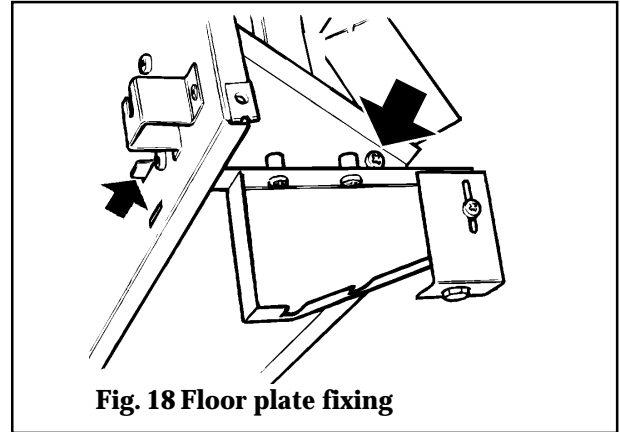

Fig. 18 Floor plate fixing

8.8. To Remove The Piezo Generator

- 8.8.1.** Remove the gas tap as section 8.4..
- 8.8.2.** Make sure that the tap is in the off position.
- 8.8.3.** Remove the circlip holding the piezo unit to the tap. Remove the piezo unit.
- 8.8.4.** Replace in the reverse order.

8.9. To Grease The Control Tap

- 8.9.1.** Detach the tap and remove the piezo generator as section 8.8 making sure that the tap is in the off position.
- 8.9.2.** Remove the two screws from the head of the tap. Remove the niting head and spindle complete with collar and spring.
- 8.9.3.** Note the position of the slot in the plug - mark its position on the tap body.
- 8.9.4.** Remove the plug rotating slightly while pulling.
- 8.9.5.** Clean and grease the plug lightly with a suitable grease. Do not apply excessive grease. Particularly, make sure that the gas ports in the tap are not restricted by grease.
- 8.9.6.** Push the plug into the tap body and position the slot in line with the mark previously made on the tap body.
- 8.9.7.** Reassemble the niting head and spindle complete with collar and spring making sure that the components are correctly engaged. Check the operation of the tap.
- 8.9.8.** Refit the piezo generator.

REPLACEMENT PARTS - SHORT LIST

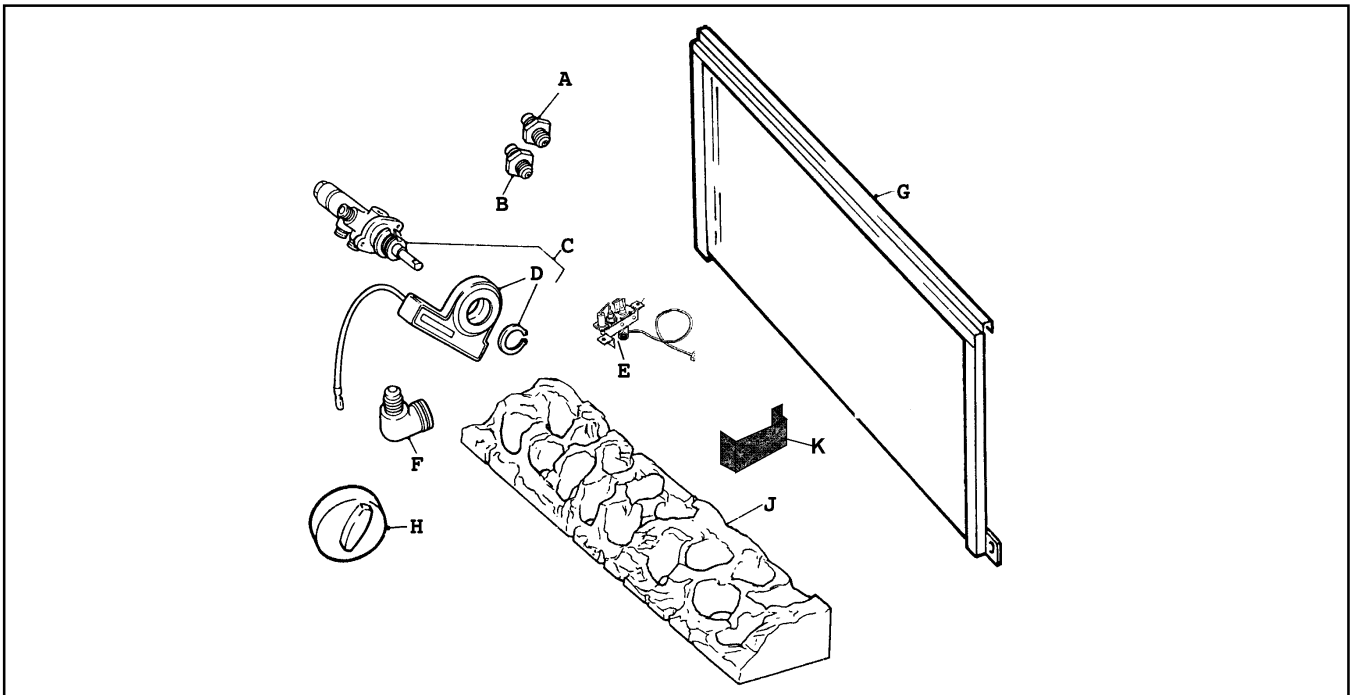

KEY NO.	DESCRIPTION	No. OFF	MAKERS PART No.
A	Injector - Upper - Bray 99 Size 150b	1	522109
B	Injector - Bray 99 Size 240	1	522809
C	Gas Tap Copreci & Spark Generator	1	558799
D	Spark Generator	1	521069
E	Pilot Unit	1	545949
F	Inlet Elbow	1	532519
G	Window Unit	1	522209
H	Control Knob	1	520799
J	Coal	1	558809
K	Dust Cage	1	567619

VALOR HEATING

ERDINGTON, BIRMINGHAM B24 9QP



Because our policy is one of constant development and improvement, details may vary slightly from those given in this publication.

© Valor Ltd